

DC 2100 version nc DUSTLESS CONNECTION

**INSTRUMENT CONNECTION
IN NON CORROSIVE MATERIAL**



Technical Data for DC 2100 version nc

Air supply:	Compressed air, minimum 6 bar (85 Psi)
Air consumption:	Only applicable when in use
Instrument connection:	1 ¼" BSP
Socket dimension:	1 ½" BSP
Dimension:	25 x 15 x 10 cm (10" x 6" x 4")
Net weight:	1.5 kg (3 lbs)
Material:	Stainless steel and brass (except for plug)
Application:	Connection for measuring instruments: Coal flow and gas velocity
Operating temperature:	Max. 150°C (302°F)

Principle of operation of DC 2100 version nc

The Dustless Connection is inserted into the mounting socket on the pulverized fuel pipe. Compressed air is connected to the DC to create an air curtain preventing coal dust from escaping from the fuel pipe. The sealing plug is removed and the DC is now ready for introduction of the measuring equipment: Coal Flow Measuring (PFS) and Dirty Air Pitot Tube (DAP).

The Company and its product line

M&W Asketeknik is an internationally working engineering company specialized in the design, manufacturing and supply of analysing and sampling systems for optimizing processes and controlling by-products in coal-fired power plants and other utility boilers. Several hundred units are successfully analysing and monitoring combustion processes in power stations world-wide.

M&W Asketeknik's product line

- Pulverized Fuel Sampler (PFS)
- Dustless Connection (DC)
- Dirty Air Pitot (DAP)
- Automatic Coal Flow Monitor (ACFM)
- Automatic Trimming Damper (ATD)
- Automatic Dust Sampler (ADS)
- Residual Carbon Analyser (RCA)
- Fly-Ash Sampler (FAS)
- Raw Coal Sampling Systems (RCS)

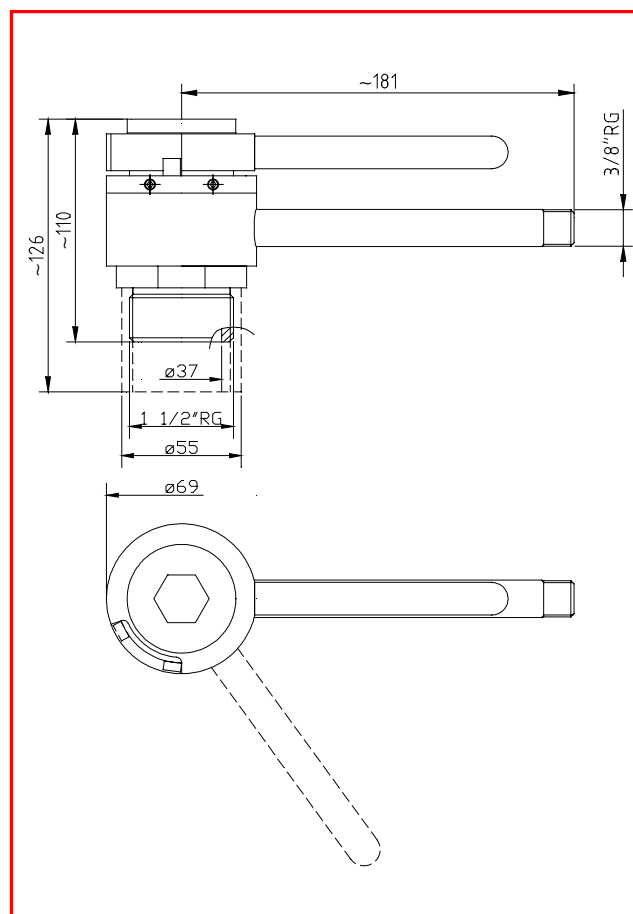

M&W ASKETEKNIK APS



ENGINEERING AND PRODUCTION
Member of the Mark & Wedell Group
Oldenvej 5, DK-3490 Kvistgaard, Denmark
Tel.: +45 49 13 98 22 Fax: +45 49 13 91 62
Internet: www.m-w.dk E-mail: m-w@m-w.dk